



# ±1°C Remote and Local TEMPERATURE SENSOR with N-Factor and Series Resistance Correction

## FEATURES

- ±1°C REMOTE DIODE SENSOR
- ±1°C LOCAL TEMPERATURE SENSOR
- PROGRAMMABLE NON-IDEALITY FACTOR
- PROGRAMMABLE SERIES RESISTANCE CANCELLATION
- ALERT FUNCTION
- PROGRAMMABLE RESOLUTION: 9 to 12 Bits
- PROGRAMMABLE THRESHOLD LIMITS
- TWO-WIRE/SMBus™ SERIAL INTERFACE
- MINIMUM AND MAXIMUM TEMPERATURE MONITORS
- MULTIPLE INTERFACE ADDRESSES
- $\overline{\text{ALERT}}$  PIN CONFIGURATION
- DIODE FAULT DETECTION

## APPLICATIONS

- LCD/DLP®/LCOS PROJECTORS
- SERVERS
- INDUSTRIAL CONTROLLERS
- CENTRAL OFFICE TELECOM EQUIPMENT
- DESKTOP AND NOTEBOOK COMPUTERS
- STORAGE AREA NETWORKS (SAN)
- INDUSTRIAL AND MEDICAL EQUIPMENT
- PROCESSOR/FPGA TEMPERATURE MONITORING

## DESCRIPTION

The TMP400 is a remote temperature sensor monitor with a built-in local temperature sensor. The remote temperature sensor diode-connected transistors are typically low-cost, NPN- or PNP-type transistors or diodes that are an integral part of microcontrollers, microprocessors, or FPGAs.

Remote accuracy is ±1°C for multiple IC manufacturers, with no calibration needed. The Two-Wire serial interface accepts SMBus write byte, read byte, send byte, and receive byte commands to program the alarm thresholds and to read temperature data.

The TMP400 is customizable with programmable: series resistance cancellation, non-ideality factor, resolution, and threshold limits. Other features are: minimum and maximum temperature monitors, wide remote temperature measurement range (up to +127.9375°C), diode fault detection, and temperature alert function.

The TMP400 is available in a QSSOP-16 package.

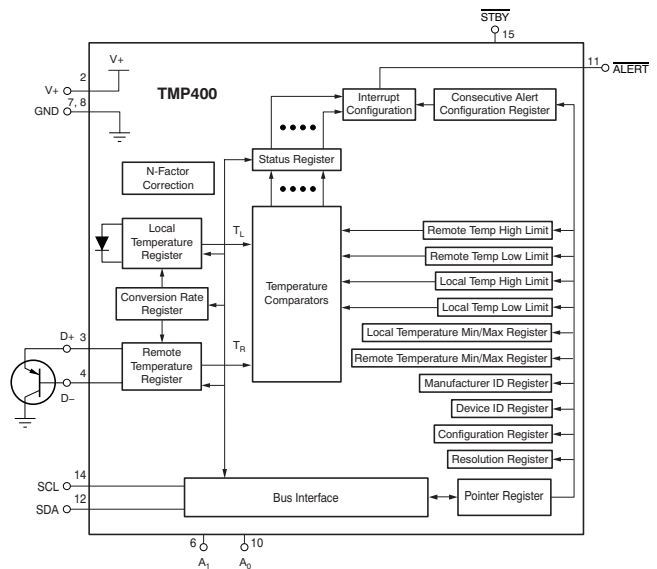

Please be aware that an important notice concerning availability, standard warranty, and use in critical applications of Texas Instruments semiconductor products and disclaimers thereto appears at the end of this data sheet.

DLP is a registered trademark of Texas Instruments.  
SMBus is a trademark of Intel Corp.  
All other trademarks are the property of their respective owners.



This integrated circuit can be damaged by ESD. Texas Instruments recommends that all integrated circuits be handled with appropriate precautions. Failure to observe proper handling and installation procedures can cause damage.

ESD damage can range from subtle performance degradation to complete device failure. Precision integrated circuits may be more susceptible to damage because very small parametric changes could cause the device not to meet its published specifications.

**ORDERING INFORMATION<sup>(1)</sup>**

PRODUCT	PACKAGE-LEAD	PACKAGE DESIGNATOR	PACKAGE MARKING
TMP400	QSSOP-16	DBQ	TMP400

(1) For the most current package and ordering information see the Package Option Addendum at the end of this document, or see the TI web site at [www.ti.com](http://www.ti.com).

**ABSOLUTE MAXIMUM RATINGS<sup>(1)</sup>**

	TMP400	UNIT
Power Supply, $V_S$	7	V
Input Voltage, pins 3, 4, 6, 10, and 15 only	-0.5 to $V_S + 0.5$	V
Input Voltage, pins 11, 12, and 14 only	-0.5 to +7	V
Input Current	10	mA
Operating Temperature Range	-55 to +127	°C
Storage Temperature Range	-60 to +130	°C
Junction Temperature ( $T_J$ max)	+150	°C
ESD Rating	Human Body Model (HBM)	3000
	Charged Device Model (CDM)	1000
	Machine Model (MM)	200

(1) Stresses above these ratings may cause permanent damage. Exposure to absolute maximum conditions for extended periods may degrade device reliability. These are stress ratings only, and functional operation of the device at these or any other conditions beyond those specified is not supported.

**PIN CONFIGURATION**

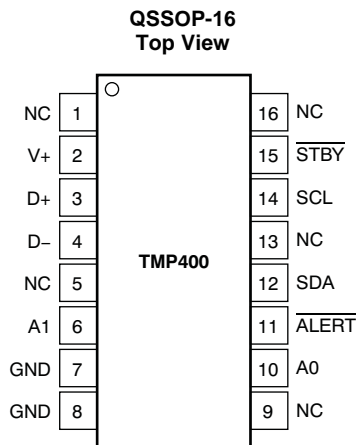

**TERMINAL FUNCTIONS**

PIN	NAME	DESCRIPTION
1, 5, 9, 13, 16	NC	No internal connection
2	V+	Positive supply (2.7V to 5.5V)
3	D+	Positive connection to remote temperature sensor
4	D-	Negative connection to remote temperature sensor
6	A1	Address pin
7, 8	GND	Ground
10	A0	Address pin
11	ALERT	Alert, active low, open-drain; requires pull-up resistor to V+
12	SDA	Serial data line for SMBus, open-drain; requires pull-up resistor to V+
14	SCL	Serial clock line for SMBus, open-drain; requires pull-up resistor to V+
15	STBY	Standby pin

## ELECTRICAL CHARACTERISTICS

 At  $T_A = -40^\circ\text{C}$  to  $+125^\circ\text{C}$  and  $V_S = 2.7\text{V}$  to  $5.5\text{V}$ , unless otherwise noted.

PARAMETER	CONDITIONS	TMP400			UNIT
		MIN	TYP	MAX	
<b>TEMPERATURE ERROR</b>					
Local Temperature Sensor	$T_{E\text{LOCAL}}$ $T_A = -40^\circ\text{C}$ to $+125^\circ\text{C}$ $V_S = 3.3\text{V}$ , $T_A = +15^\circ\text{C}$ to $+85^\circ\text{C}$		$\pm 1.25$	$\pm 2.5$	$^\circ\text{C}$
Remote Temperature Sensor <sup>(1)(2)</sup>	$T_{E\text{REMOTE}}$ $V_S = 3.3\text{V}$ , $T_A = +15^\circ\text{C}$ to $+75^\circ\text{C}$ , $T_D = -40^\circ\text{C}$ to $+125^\circ\text{C}$ <sup>(3)</sup> $V_S = 3.3\text{V}$ , $T_A = -40^\circ\text{C}$ to $+100^\circ\text{C}$ , $T_D = -40^\circ\text{C}$ to $+125^\circ\text{C}$ <sup>(3)</sup> $T_A = -40^\circ\text{C}$ to $+125^\circ\text{C}$ , $T_D = -40^\circ\text{C}$ to $+125^\circ\text{C}$ <sup>(3)</sup>		$\pm 0.0625$	$\pm 1$	$^\circ\text{C}$
vs Supply			$\pm 1$	$\pm 3$	$^\circ\text{C}$
Local/Remote	$V_S = 2.7\text{V}$ to $5.5\text{V}$		$\pm 3$	$\pm 10$	$^\circ\text{C}$
			$\pm 0.2$	$\pm 0.5$	$^\circ\text{C/V}$
<b>TEMPERATURE MEASUREMENT</b>					
Conversion Time (per channel) <sup>(4)</sup>		105	115	125	ms
Resolution					
Local Temperature Sensor (programmable)		9		12	Bits
Remote Temperature Sensor			12		Bits
Remote Sensor Source Currents					
High	Series Resistance 3k $\Omega$ Maximum		120		$\mu\text{A}$
Medium High			60		$\mu\text{A}$
Medium Low			12		$\mu\text{A}$
Low			6		$\mu\text{A}$
Remote Transistor Ideality Factor	$\eta$ TMP400 Optimized Ideality Factor		1.008		
<b>SMBus INTERFACE</b>					
Logic Input High Voltage (SCL, SDA)	$V_{IH}$	2.1			V
Logic Input Low Voltage (SCL, SDA)	$V_{IL}$			0.8	V
Hysteresis			500		mV
SMBus Output Low Sink Current		6			mA
Logic Input Current		-1		+1	$\mu\text{A}$
SMBus Input Capacitance (SCL, SDA)			3		pF
SMBus Clock Frequency				3.4	MHz
SMBus Timeout		25	30	35	ms
SCL Falling Edge to SDA Valid Time				1	$\mu\text{s}$
<b>DIGITAL OUTPUTS</b>					
Output Low Voltage	$V_{OL}$		0.15	0.4	V
High-Level Output Leakage Current	$I_{OH}$		0.1	1	$\mu\text{A}$
$\overline{\text{ALERT}}$ Output Low Sink Current	$\overline{\text{ALERT}}$ Forced to 0.4V	6			mA
<b>POWER SUPPLY</b>					
Specified Voltage Range	$V_S$	2.7		5.5	V
Quiescent Current	$I_Q$				
	0.0625 Conversions per Second		30	38	$\mu\text{A}$
	Eight Conversions per Second		420	525	$\mu\text{A}$
	Serial Bus Inactive, Shutdown Mode		3	10	$\mu\text{A}$
	Serial Bus Active, $f_S = 400\text{kHz}$ , Shutdown Mode		90		$\mu\text{A}$
	Serial Bus Active, $f_S = 3.4\text{MHz}$ , Shutdown Mode		350		$\mu\text{A}$
Undervoltage Lock Out		2.3	2.4	2.6	V
Power-On Reset Threshold	POR		1.6	2.3	V
<b>TEMPERATURE RANGE</b>					
Specified Range		-40		+125	$^\circ\text{C}$
Storage Range		-60		+130	$^\circ\text{C}$
Thermal Resistance, QSSOP			70		$^\circ\text{C/W}$

 (1) Tested with less than 5 $\Omega$  effective series resistance and 100pF differential input capacitance.

(2) RC = '1'.

 (3)  $T_D$  is the remote temperature measured at the diode.

(4) RES1 = '1' and RES0 = '1' for 12-bit resolution.

**TYPICAL CHARACTERISTICS**

At  $T_A = +25^\circ\text{C}$  and  $V_S = 5.0\text{V}$ , unless otherwise noted.

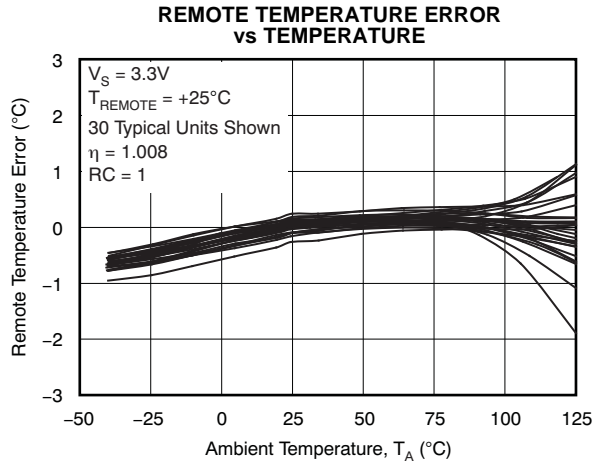

Figure 1.

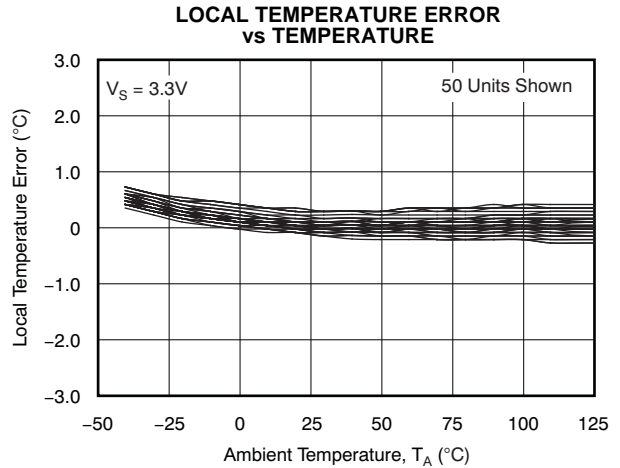

Figure 2.

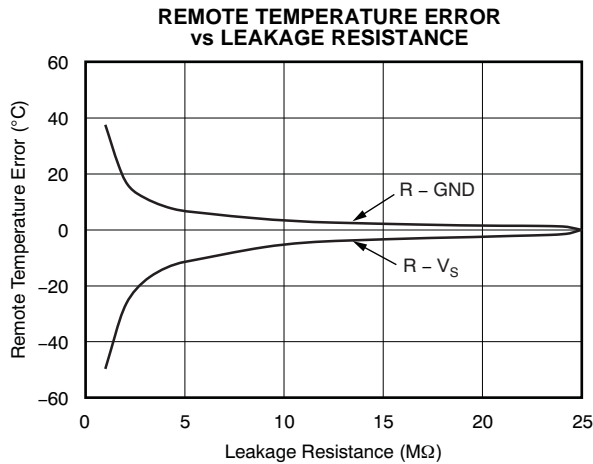

Figure 3.

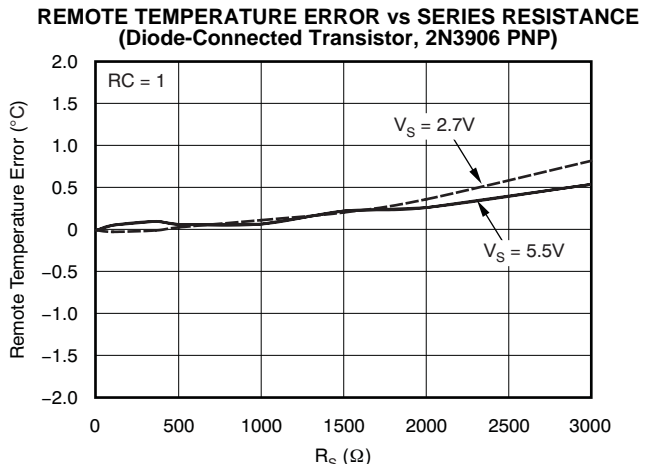

Figure 4.

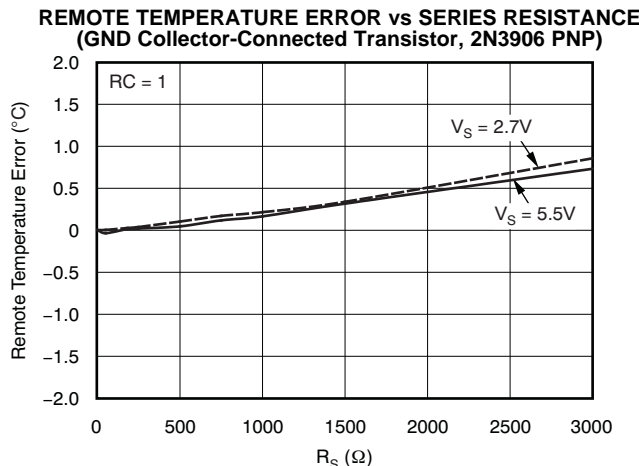

Figure 5.

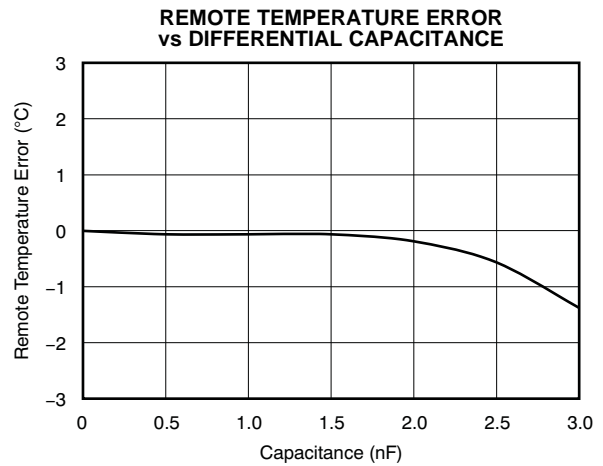
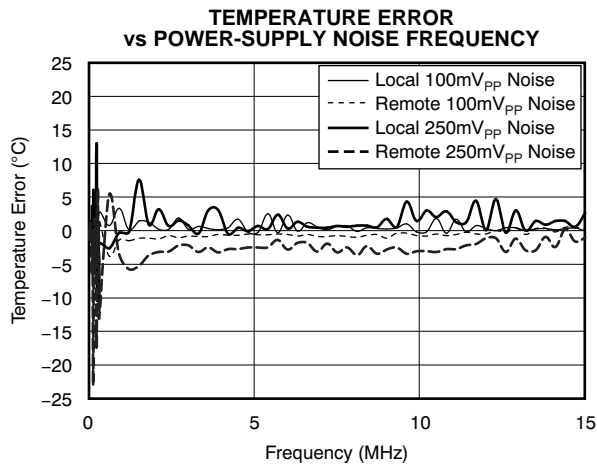

Figure 6.

**TYPICAL CHARACTERISTICS (continued)**

At  $T_A = +25^\circ\text{C}$  and  $V_S = 5.0\text{V}$ , unless otherwise noted.



**Figure 7.**

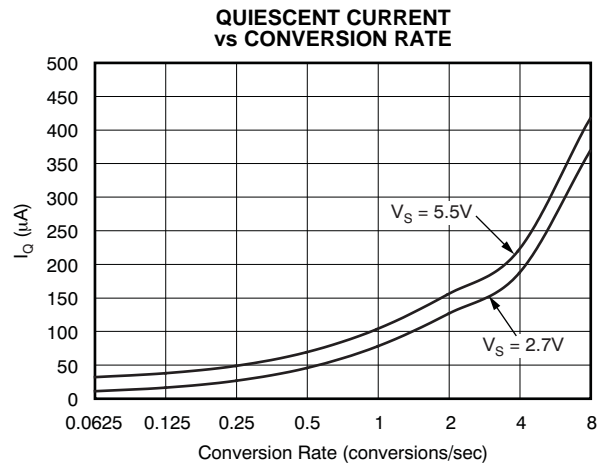

**Figure 8.**

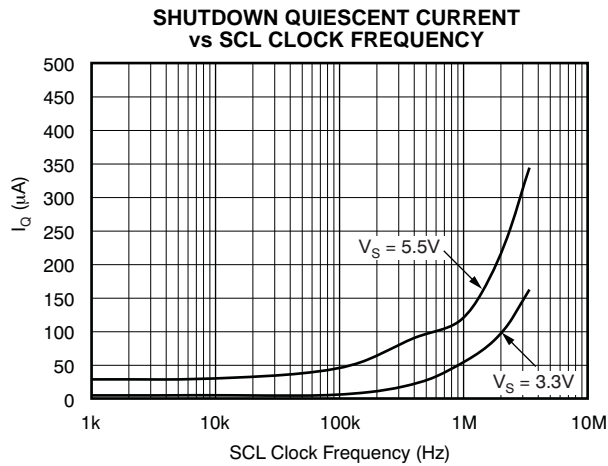

**Figure 9.**

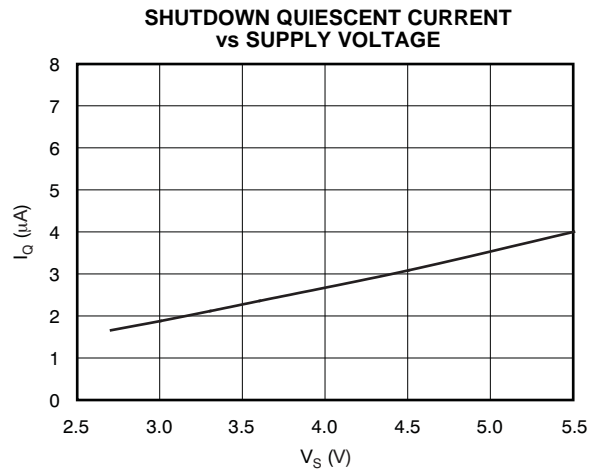

**Figure 10.**

### APPLICATION INFORMATION

The TMP400 is a dual-channel digital temperature sensor that combines a local die temperature measurement channel and a remote junction temperature measurement channel in a QSSOP-16 package. The TMP400 is Two-Wire and SMBus interface-compatible, and is specified over a temperature range of  $-40^{\circ}\text{C}$  to  $+125^{\circ}\text{C}$ . The TMP400 contains multiple registers for holding configuration information, temperature measurement results, temperature comparator maximum/minimum limits, and status information.

User-programmed high and low temperature limits stored in the TMP400 can be used to monitor local and remote temperatures to trigger an over/under temperature alarm ( $\overline{\text{ALERT}}$ ).

The TMP400 requires only a transistor connected between D+ and D- for proper remote temperature sensing operation. The SCL and SDA interface pins require pull-up resistors as part of the communication bus, while  $\overline{\text{ALERT}}$  is an open-drain output that also needs a pull-up resistor.  $\overline{\text{ALERT}}$  may be shared with

other devices if desired for a wired-OR implementation. A  $0.1\mu\text{F}$  power-supply bypass capacitor is recommended for good local bypassing. Figure 11 shows a typical configuration for the TMP400.

### SERIES RESISTANCE CANCELLATION

Series resistance in an application circuit that typically results from printed circuit board (PCB) trace resistance and remote line length (see Figure 11) can be automatically programmed to be cancelled by the TMP400 by setting the RC bit to '1' in the Resolution Register, preventing what would otherwise result in a temperature offset.

A total of up to  $3\text{k}\Omega$  of series line resistance is cancelled by the TMP400 if the RC bit is enabled, eliminating the need for additional characterization and temperature offset correction. Upon power-up, the RC bit is disabled ( $\text{RC} = 0$ ).

See the two *Remote Temperature Error vs Series Resistance* typical characteristics curves (Figure 4 and Figure 5) for details on the effect of series resistance and power-supply voltage on sensed remote temperature error.

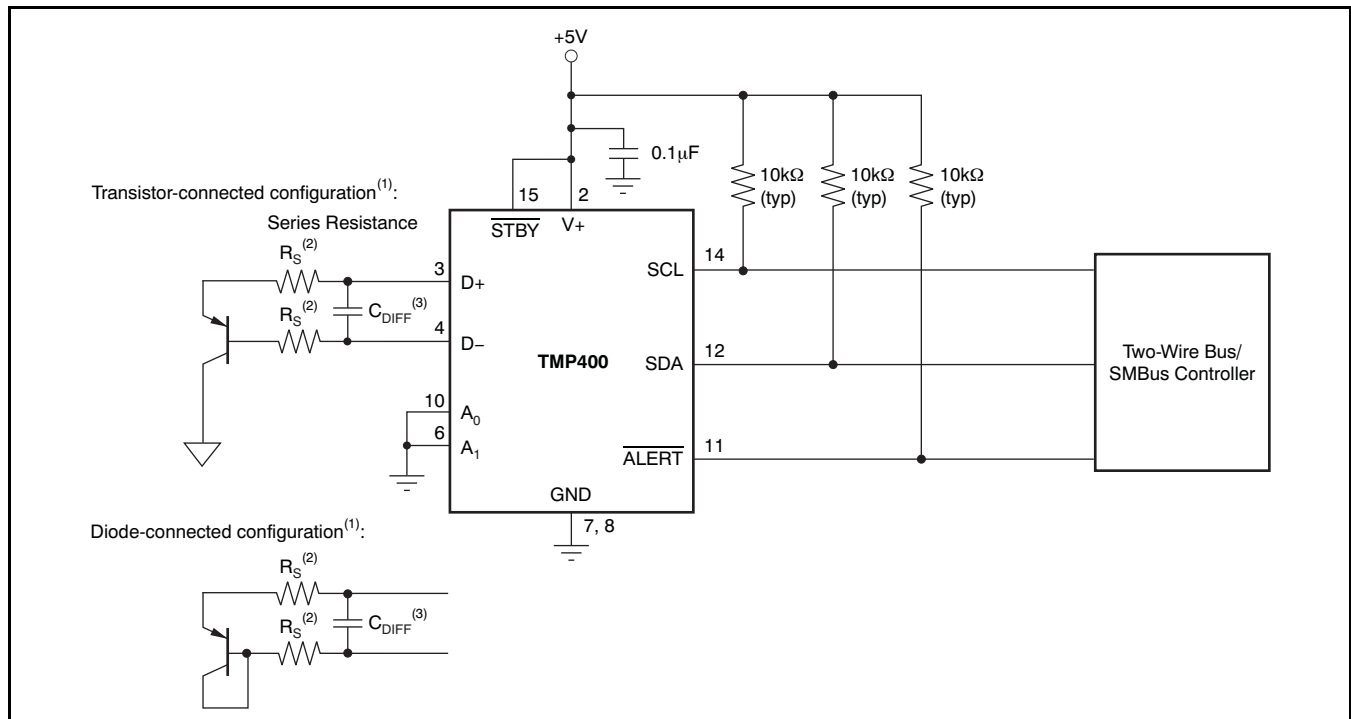

(1) Diode-connected configuration provides better settling time. Transistor-connected configuration provides better series resistance cancellation.

(2)  $R_S$  should be less than  $1.5\text{k}\Omega$  in most applications.

(3)  $C_{\text{DIFF}}$  should be less than  $1000\text{pF}$  in most applications.

Figure 11. Basic Connections

## DIFFERENTIAL INPUT CAPACITANCE

The TMP400 tolerates differential input capacitance of up to 1000pF if RC = 1 (if RC = 0, input capacitance can be as high as 2200pF) with minimal change in temperature error. The effect of capacitance on sensed remote temperature error is illustrated in the typical characteristic curve, *Remote Temperature Error vs Differential Capacitance* (Figure 6).

## TEMPERATURE MEASUREMENT DATA

Temperature measurement data are taken over a default range of  $-55^{\circ}\text{C}$  to  $+127.9375^{\circ}\text{C}$  for both local and remote locations.

Temperature data resulting from conversions within the default measurement range are represented in binary form, as shown in Table 1, Binary column. Note that any temperature above  $+127.9375^{\circ}\text{C}$  results in a value of 127.9375 (7Fh/F0h). Temperatures below  $-65^{\circ}\text{C}$  results in a value of  $-65$  (BF/00h). The TMP400 is specified only for ambient temperatures ranging from  $-40^{\circ}\text{C}$  to  $+125^{\circ}\text{C}$ . Parameters in the [Absolute Maximum Ratings](#) table must be observed.

Table 1. Temperature Data Format

TEMPERATURE ( $^{\circ}\text{C}$ )	REMOTE TEMPERATURE REGISTER		
	DIGITAL OUTPUT (BINARY)		HEX
	HIGH BYTE	LOW BYTE	
128	0111 1111	1111 0000	7F/F0
127.9375	0111 1111	1111 0000	7F/F0
100	0110 0100	0000 0000	64/00
80	0101 0000	0000 0000	50/00
75	0100 1011	0000 0000	4B/00
50	0011 0010	0000 0000	32/00
25	0001 1001	0000 0000	19/00
0.25	0000 0000	0100 0000	00/40
0	0000 0000	0000 0000	00/00
$-0.25$	1111 1111	1100 0000	FF/C0
$-25$	1110 0111	0000 0000	E7/00
$-55$	1100 1001	0000 0000	C9/00
$-65$	1011 1111	0000 0000	BF/00

Both local and remote temperature data use two bytes for data storage. The high byte stores the temperature with  $1^{\circ}\text{C}$  resolution. The second (or low)

byte stores the decimal fraction value of the temperature and allows a higher measurement resolution. The measurement resolution for the remote channel is  $0.0625^{\circ}\text{C}$ , and is not adjustable. The measurement resolution for the local channel is adjustable; it can be set for  $0.5^{\circ}\text{C}$ ,  $0.25^{\circ}\text{C}$ ,  $0.125^{\circ}\text{C}$ , or  $0.0625^{\circ}\text{C}$  by setting the RES1 and RES0 bits of the Resolution Register; see the [Resolution Register](#) section (Table 5).

## REGISTER INFORMATION

The TMP400 contains multiple registers for holding configuration information, temperature measurement results, temperature comparator maximum/minimum, limits, and status information. These registers are described in Figure 12 and Table 2.

## POINTER REGISTER

Figure 12 shows the internal register structure of the TMP400. The 8-bit Pointer Register is used to address a given data register. The Pointer Register identifies which of the data registers should respond to a read or write command on the Two-Wire bus. This register is set with every write command. A write command must be issued to set the proper value in the Pointer Register before executing a read command. Table 2 describes the pointer address of the registers available in the TMP400. The power-on reset (POR) value of the Pointer Register is 00h (0000 0000b).

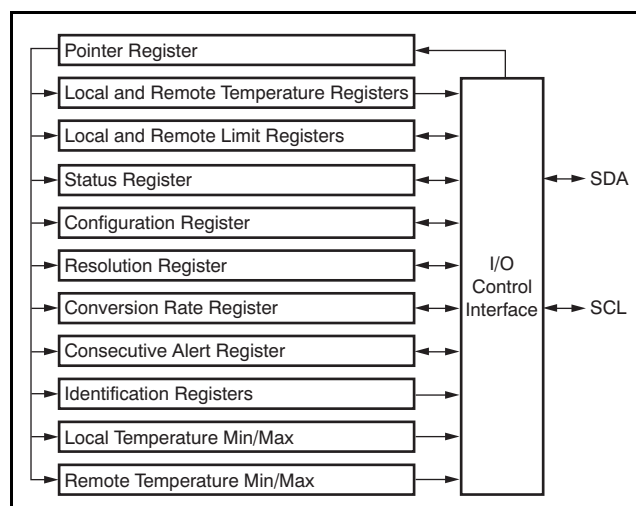

Figure 12. Internal Register Structure

**Table 2. Register Map**

POINTER ADDRESS (HEX)		POWER-ON RESET (HEX)	BIT DESCRIPTIONS								REGISTER DESCRIPTIONS
READ	WRITE		D7	D6	D5	D4	D3	D2	D1	D0	
00	NA <sup>(1)</sup>	00	LT11	LT10	LT9	LT8	LT7	LT6	LT5	LT4	Local Temperature (High Byte)
01	NA	00	RT11	RT10	RT9	RT8	RT7	RT6	RT5	RT4	Remote Temperature (High Byte)
02	NA	00	BUSY	LHIGH	LOW	RHIGH	RLOW	OPEN	0	0	Status Register
03	09	00	MASK1	SD	0	0	0	0	0	0	Configuration Register
04	0A	02	0	0	0	0	R3	R2	R1	R0	Conversion Rate Register
05	0B	7F	LTH11	LTH10	LTH9	LTH8	LTH7	LTH6	LTH5	LTH4	Local Temperature High Limit (High Byte)
06	0C	C9	LTL11	LTL10	LTL9	LTL8	LTL7	LTL6	LTL5	LTL4	Local Temperature Low Limit (High Byte)
07	0D	7F	RTH11	RTH10	RTH9	RTH8	RTH7	RTH6	RTH5	RTH4	Remote Temperature High Limit (High Byte)
08	0E	C9	RTL11	RTL10	RTL9	RTL8	RTL7	RTL6	RTL5	RTL4	Remote Temperature Low Limit (High Byte)
NA	0F	XX	X <sup>(2)</sup>	X	X	X	X	X	X	X	One-Shot Start
10	NA	00	RT3	RT2	RT1	RT0	0	0	0	0	Remote Temperature (Low Byte)
13	13	00	RTH3	RTH2	RTH1	RTH0	0	0	0	0	Remote Temperature High Limit (Low Byte)
14	14	00	RTL3	RTL2	RTL1	RTL0	0	0	0	0	Remote Temperature Low Limit (Low Byte)
15	NA	00	LT3	LT2	LT1	LT0	0	0	0	0	Local Temperature (Low Byte)
16	16	00	LTH3	LTH2	LTH1	LTH0	0	0	0	0	Local Temperature High Limit (Low Byte)
17	17	00	LTL3	LTL2	LTL1	LTL0	0	0	0	0	Local Temperature Low Limit (Low Byte)
18	18	00	NC7	NC6	NC5	NC4	NC3	NC2	NC1	NC0	N-factor Correction
1A	1A	18	0	0	0	1	1	RC	RES1	RES0	Resolution Register
22	22	01	TO_EN	0	0	0	C2	C1	C0	0	Consecutive Alert Register
30	30	7F	LMT11	LMT10	LMT9	LMT8	LMT7	LMT6	LMT5	LMT4	Local Temperature Minimum (High Byte)
31	31	F0	LMT3	LMT2	LMT1	LMT0	0	0	0	0	Local Temperature Minimum (Low Byte)
32	32	80	LXT11	LXT10	LXT9	LXT8	LXT7	LXT6	LXT5	LXT4	Local Temperature Maximum (High Byte)
33	33	00	LXT3	LXT2	LXT1	LXT0	0	0	0	0	Local Temperature Maximum (Low Byte)
34	34	7F	RMT11	RMT10	RMT9	RMT8	RMT7	RMT6	RMT5	RMT4	Remote Temperature Minimum (High Byte)
35	35	F0	RMT3	RMT2	RMT1	RMT0	0	0	0	0	Remote Temperature Minimum (Low Byte)
36	36	80	RXT11	RXT10	RXT9	RXT8	RXT7	RXT6	RXT5	RXT4	Remote Temperature Maximum (High Byte)
37	37	00	RXT3	RXT2	RXT1	RXT0	0	0	0	0	Remote Temperature Maximum (Low Byte)
NA	FC	FF	X <sup>(2)</sup>	X	X	X	X	X	X	X	Software Reset
FE	NA	55	0	1	0	1	0	1	0	1	Manufacturer ID
FF	NA	01	0	0	0	0	0	0	0	1	Device ID

(1) NA = not applicable; register is write- or read-only.

(2) X = indeterminate state. Writing any value to this register indicates a software reset; see the [Software Reset](#) section.

## TEMPERATURE REGISTERS

The TMP400 has four 8-bit registers that hold temperature measurement results. Both the local channel and the remote channel have a high byte register that contains the most significant bits (MSBs) of the temperature analog-to-digital converter (ADC) result, and a low byte register that contains the least significant bits (LSBs) of the temperature ADC result. The local channel high byte address is 00h; the local channel low byte address is 15h. The remote channel high byte is at address 01h; the remote channel low byte address is 10h. These read-only registers are updated by the ADC each time a temperature measurement is completed.

The TMP400 contains circuitry to assure that a low byte register read command returns data from the same ADC conversion as the immediately preceding high byte read command. This assurance remains valid only until another register is read. For proper operation, the high byte of a temperature register should be read first. The low byte register should be read in the next read command. The low byte register may be left unread if the LSBs are not needed. Alternatively, the temperature registers may be read as a 16-bit register by using a single two-byte read command from address 00h for the local channel result or from address 01h for the remote channel result. The high byte is output first, followed by the low byte. Both bytes of this read operation are from the same ADC conversion. The power-on reset value of both temperature registers is 00h.

## LIMIT REGISTERS

The TMP400 has eight registers for setting comparator limits for both the local and remote measurement channels. These registers have read and write capability. The High and Low Limit Registers for both channels span two registers, as do the temperature registers. The local temperature high limit is set by writing the high byte to pointer address 0Bh and writing the low byte to pointer address 16h, or by using a single two-byte write command (high

byte first) to pointer address 0Bh. The local temperature high limit is obtained by reading the high byte from pointer address 05h and the low byte from pointer address 16h. The power-on reset value of the local temperature high limit is 7Fh/00h (+127°C).

Similarly, the local temperature low limit is set by writing the high byte to pointer address 0Ch and writing the low byte to pointer address 17h, or by using a single two-byte write command to pointer address 0Ch. The local temperature low limit is read by reading the high byte from pointer address 06h and the low byte from pointer address 17h, or by using a two-byte read from pointer address 06h. The power-on reset value of the local temperature low limit register is C9h/00h (–55°C).

The remote temperature high limit is set by writing the high byte to pointer address 0Dh and writing the low byte to pointer address 13h, or by using a two-byte write command to pointer address 0Dh. The remote temperature high limit is obtained by reading the high byte from pointer address 07h and the low byte from pointer address 13h, or by using a two-byte read command from pointer address 07h. The power-on reset value of the Remote Temperature High Limit Register is 7Fh/00h (+127°C).

The remote temperature low limit is set by writing the high byte to pointer address 0Eh and writing the low byte to pointer address 14h, or by using a two-byte write to pointer address 0Eh. The remote temperature low limit is read by reading the high byte from pointer address 08h and the low byte from pointer address 14h, or by using a two-byte read from pointer address 08h. The power-on reset value of the Remote Temperature Low Limit Register is C9h/00h (–55°C).

## STATUS REGISTER

The TMP400 has a Status Register to report the state of the temperature comparators. [Table 3](#) shows the Status Register bits. The Status Register is read-only and is read by reading from pointer address 02h.

**Table 3. Status Register Format**

STATUS REGISTER (Read = 02h, Write = NA)								
BIT #	D7	D6	D5	D4	D3	D2	D1	D0
BIT NAME	BUSY	LHIGH	LOW	RHIGH	RLOW	OPEN	—	—
POR VALUE	0 <sup>(1)</sup>	0	0	0	0	0	0	0

(1) The BUSY bit will change to '1' almost immediately (<< 100μs) following power-up, as the TMP400 begins the first temperature conversion. It is high whenever the TMP400 converts a temperature reading.

The BUSY bit is '1' if the ADC makes a conversion. It is '0' if the ADC is not converting.

The OPEN bit is '1' if the remote transistor was detected as open since the last read of the Status Register. The OPEN status is only detected when the ADC attempts to convert a remote temperature.

The LHIGH bit is '1' if the local high limit was exceeded since the last clearing of the Status Register. The RHIGH bit is '1' if the remote high limit was exceeded since the last clearing of the Status Register.

The LLOW bit is '1' if the local low limit was exceeded since the last clearing of the Status Register. The RLOW bit is '1' if the remote low limit was exceeded since the last clearing of the Status Register.

The values of the LLOW, RLOW, and OPEN bits are latched and read as '1' until the Status Register is read or a device reset occurs. These bits are cleared by reading the Status Register, provided that the condition causing the flag to be set no longer exists. The BUSY bit is not latched and is not cleared by reading the Status Register. The BUSY bit always indicates the current state and updates appropriately at the end of the corresponding ADC conversion. Clearing the Status Register bits does not clear the state of the  $\overline{\text{ALERT}}$  pin; an SMBus alert response address command must be used to clear the  $\overline{\text{ALERT}}$  pin.

The TMP400 NORs LHIGH, LLOW, RHIGH, RLOW, and OPEN, so a status change for any of these flags from '0' to '1' automatically causes the  $\overline{\text{ALERT}}$  pin to go low.

### CONFIGURATION REGISTER

The Configuration Register controls shutdown mode and disables the  $\overline{\text{ALERT}}$  pin. The Configuration Register is set by writing to pointer address 09h and read by reading from pointer address 03h.

The MASK bit (bit 7) enables or disables the  $\overline{\text{ALERT}}$  pin output. If MASK is set to '0', the  $\overline{\text{ALERT}}$  pin goes low when one of the temperature measurement channels exceeds its high or low limits for the chosen number of consecutive conversions. If the MASK bit is set to '1', the TMP400 retains the  $\overline{\text{ALERT}}$  pin status, but the  $\overline{\text{ALERT}}$  pin does not go low.

The shutdown (SD) bit (bit 6) enables or disables the temperature measurement circuitry. If SD = 0, the TMP400 converts continuously at the rate set in the conversion rate register. When SD is set to '1', the TMP400 immediately stops converting and enters a shutdown mode. When SD is set to '0' again, the TMP400 resumes continuous conversions.

The remaining bits of the Configuration Register are reserved and must always be set to '0'. The power-on reset value for this register is 00h. [Table 4](#) summarizes the bits of the Configuration Register.

**Table 4. Configuration Register Bit Descriptions**

CONFIGURATION REGISTER (Read = 03h, Write = 09h, POR = 00h)			
BIT	NAME	FUNCTION	POWER-ON RESET VALUE
7	MASK	0 = ALERT Enabled 1 = ALERT Masked	0
6	SD	0 = Run 1 = Shut Down	0
5, 4, 3, 2, 1, 0	Reserved	—	0

## RESOLUTION REGISTER

The RES1 and RES0 bits (resolution bits 1 and 0, respectively) of the Resolution Register set the resolution of the local temperature measurement channel. Remote temperature measurement channel resolution is not affected. Changing the local channel resolution also affects the conversion time and rate of the TMP400. The Resolution Register is set by writing to pointer address 1Ah and is read by reading from pointer address 1Ah. [Table 5](#) shows the resolution bits for the Resolution Register.

**Table 5. Resolution Register: Local Channel Programmable Resolution**

RESOLUTION REGISTER (Read = 1Ah, Write = 1Ah, POR = 18h)			
RES1	RES0	RESOLUTION	CONVERSION TIME (Typical)
0	0	9 Bits (0.5°C)	12.5ms
0	1	10 Bits (0.25°C)	25ms
1	0	11 Bits (0.125°C)	50ms
1	1	12 Bits (0.0625°C)	100ms

Bits 3 and 4 of the Resolution Register must always be set to '1'. Bits 5 through 7 of the Resolution Register must always be set to '0'. The power-on reset value of this register is 18h. Resistance correction (RC) is not automatically enabled on power-on; see the [Series Resistance Cancellation](#) section for information on RC.

## ONE-SHOT (OS)

The TMP400 features a One-Shot Temperature Measurement Mode. When the device is in Shutdown Mode, writing a '1' to the OS bit starts a single temperature conversion. The device returns to the shutdown state at the completion of the single

conversion. This mode is useful to reduce power consumption in the TMP400 when continuous temperature monitoring is not required. When the configuration register is read, the OS bit always reads '0'.

## CONVERSION RATE REGISTER

The Conversion Rate Register controls the rate at which temperature conversions are performed. This register adjusts the idle time between conversions but not the conversion timing itself, thereby allowing the TMP400 power dissipation to be balanced with the temperature register update rate. [Table 6](#) shows the conversion rate options and corresponding current consumption. By default, the TMP400 converts every four seconds.

## N-FACTOR CORRECTION REGISTER

The TMP400 allows for a different *n*-factor value to be used for converting remote channel measurements to temperature. The remote channel uses sequential current excitation to extract a differential  $V_{BE}$  voltage measurement to determine the temperature of the remote transistor. [Equation 1](#) relates this voltage and temperature.

$$V_{BE2} - V_{BE1} = \frac{nkT}{q} \ln \left( \frac{I_2}{I_1} \right) \tag{1}$$

The value *n* in [Equation 1](#) is a characteristic of the particular transistor used for the remote channel. The default value for the TMP400 is *n* = 1.008. The value in the N-Factor Correction Register may be used to adjust the effective *n*-factor according to [Equation 2](#) and [Equation 3](#).

$$n_{eff} = \frac{1.008 \times 300}{(300 - N_{ADJUST})} \tag{2}$$

$$N_{ADJUST} = 300 - \left( \frac{300 \times 1.008}{n_{eff}} \right) \tag{3}$$

**Table 6. Conversion Rate Register**

CONVERSION RATE REGISTER (Read = 04h, Write = 0Ah, POR = 02h)										
R7	R6	R5	R4	R3	R2	R1	R0	CONVERSION/SEC	AVERAGE $I_Q$ (TYP) ( $\mu$ A)	
									$V_S = 2.7V$	$V_S = 5.5V$
0	0	0	0	0	0	0	0	0.0625	11	32
0	0	0	0	0	0	0	1	0.125	17	38
0	0	0	0	0	0	1	0	0.25	28	49
0	0	0	0	0	0	1	1	0.5	47	69
0	0	0	0	0	1	0	0	1	80	103
0	0	0	0	0	1	0	1	2	128	155
0	0	0	0	0	1	1	0	4	190	220
07h to 0Fh								8	373	413

The *n*-correction value must be stored in two's-complement format, yielding an effective data range from –128 to +127. The *n*-correction value may be written to and read from pointer address 18h. The register power-on reset value is 00h; thus, the register has no effect unless written to. The *n*-factor range is shown in [Table 7](#).

**Table 7. N-Factor Range**

N <sub>ADJUST</sub>			N
BINARY	HEX	DECIMAL	
01111111	7F	127	1.747977
00001010	0A	10	1.042759
00001000	08	8	1.035616
00000110	06	6	1.028571
00000100	04	4	1.021622
00000010	02	2	1.014765
00000001	01	1	1.011371
00000000	00	0	1.008
11111111	FF	–1	1.004651
11111110	FE	–2	1.001325
11111100	FC	–4	0.994737
11111010	FA	–6	0.988235
11111000	F8	–8	0.981818
11110110	F6	–10	0.975484
10000000	80	–128	0.706542

**MINIMUM AND MAXIMUM REGISTERS**

The TMP400 stores the minimum and maximum temperatures measured since power-on, chip-reset, or minimum and maximum register reset for both the local and remote channels. The Local Temperature Minimum Register may be read by reading the high byte from pointer address 30h and the low byte from pointer address 31h. The Local Temperature Minimum Register may also be read by using a two-byte read command from pointer address 30h. The Local Temperature Minimum Register is reset at power-on, by executing the chip-reset command, or by writing any value to any of pointer addresses 30h through 37h. The reset value for these registers is 7Fh/F0h.

The Local Temperature Maximum Register may be read by reading the high byte from pointer address 32h and the low byte from pointer address 33h. The Local Temperature Maximum Register may also be read by using a two-byte read command from pointer address 32h. The Local Temperature Maximum Register is reset at power-on by executing the chip reset command, or by writing any value to any of pointer addresses 30h through 37h. The reset value for these registers is 80h/00h.

The Remote Temperature Minimum Register may be read by reading the high byte from pointer address 34h and the low byte from pointer address 35h. The Remote Temperature Minimum Register may also be read by using a two-byte read command from pointer address 34h. The Remote Temperature Minimum Register is reset at power-on by executing the chip reset command, or by writing any value to any of pointer addresses 30h through 37h. The reset value for these registers is 7Fh/F0h.

The Remote Temperature Maximum Register may be read by reading the high byte from pointer address 36h and the low byte from pointer address 37h. The Remote Temperature Maximum Register may also be read by using a two-byte read command from pointer address 36h. The Remote Temperature Maximum Register is reset at power-on by executing the chip reset command, or by writing any value to any of pointer addresses 30h through 37h. The reset value for these registers is 80h/00h.

**SOFTWARE RESET**

The TMP400 may be reset by writing any value to Pointer Register FCh. A reset restores the power-on reset state to all of the TMP400 registers as well as aborts any conversion in process and clears the ALERT pin.

The TMP400 also supports reset via the Two-Wire general call address (00000000). The TMP400 acknowledges the general call address and responds to the second byte. If the second byte is 00000110, the TMP400 latches the status of the address pins and executes a software reset. A 500µs time delay must be observed after a general-call command. The TMP400 takes no action in response to other values in the second byte.

## CONSECUTIVE ALERT REGISTER

The value in the Consecutive Alert Register (address 22h) determines how many consecutive out-of-limit measurements must occur on a measurement channel before the  $\overline{\text{ALERT}}$  signal is activated. The value in this register does not affect bits in the Status Register. Values of one, two, three, or four consecutive conversions can be selected; one conversion is the default. This function allows additional filtering for the  $\overline{\text{ALERT}}$  pin. The consecutive alert bits are shown in [Table 8](#).

**Table 8. Consecutive Alert Register**

CONSECUTIVE ALERT REGISTER (READ = 22h, WRITE = 22h, POR = 01h)			NUMBER OF CONSECUTIVE OUT-OF-LIMIT MEASUREMENTS
C2	C1	C0	
0	0	0	1
0	0	1	2
0	1	1	3
1	1	1	4

(1) Note that bit 7 of the Consecutive Alert Register controls the enable/disable of the timeout function. See the [Timeout Function](#) section for a description of this feature.

## BUS OVERVIEW

The TMP400 is SMBus interface-compatible. In SMBus protocol, the device that initiates the transfer is called a *master*, and the devices controlled by the master are *slaves*. The bus must be controlled by a master device that generates the serial clock (SCL), controls the bus access, and generates the START and STOP conditions.

To address a specific device, a START condition is initiated. START is indicated by pulling the data line (SDA) from a high to low logic level while SCL is high. All slaves on the bus shift in the slave address byte, with the last bit indicating whether a read or write operation is intended. During the ninth clock pulse, the slave being addressed responds to the master by generating an Acknowledge and pulling SDA low.

Data transfer is then initiated and sent over eight clock pulses followed by an Acknowledge bit. During data transfer, SDA must remain stable while SCL is high, because any change in SDA while SCL is high is interpreted as a control signal.

Once all data have been transferred, the master generates a STOP condition. STOP is indicated by pulling SDA from low to high, while SCL is high.

## SERIAL INTERFACE

The TMP400 operates only as a slave device on either the Two-Wire bus or the SMBus. Connections to either bus are made via the open-drain I/O lines, SDA, and SCL. The SDA and SCL pins feature integrated spike suppression filters and Schmitt triggers to minimize the effects of input spikes and bus noise. The TMP400 supports the transmission protocol for fast (1kHz to 400kHz) and high-speed (1kHz to 3.4MHz) modes. All data bytes are transmitted MSB first.

## SERIAL BUS ADDRESS

To communicate with the TMP400, the master must first address slave devices via a slave address byte. The slave address byte consists of seven address bits, and a direction bit indicating the intent of executing a read or write operation. The address of the TMP400 is set by the A0 and A1 pins. TMP400 addresses and corresponding A0 and A1 configurations are shown in [Table 9](#).

**Table 9. Device Addresses**

A0	A1	ADDRESS
GND	GND	0011 000
GND	High-Z	0011 001
GND	V <sub>CC</sub>	0011 010
High-Z	GND	0101 001
High-Z	High-Z	0101 010
High-Z	V <sub>CC</sub>	0101 011
V <sub>CC</sub>	GND	1001 100
V <sub>CC</sub>	High-Z	1001 101
V <sub>CC</sub>	V <sub>CC</sub>	1001 110

## READ/WRITE OPERATIONS

Accessing a particular register on the TMP400 is accomplished by writing the appropriate value to the Pointer Register. The value for the Pointer Register is the first byte transferred after the slave address byte with the R/ $\overline{\text{W}}$  bit low. Every write operation to the TMP400 requires a value for the Pointer Register (see [Figure 14](#)).

When reading from the TMP400, the last value stored in the Pointer Register by a write operation is used to determine which register is read by a read operation. To change the register pointer for a read operation, a new value must be written to the Pointer Register. This transaction is accomplished by issuing a slave address byte with the R/ $\overline{\text{W}}$  bit low, followed by the Pointer Register byte. No additional data are required. The master can then generate a START condition and send the slave address byte with the R/ $\overline{\text{W}}$  bit high to initiate the read command. See [Figure 16](#) for details of this sequence. If repeated

reads from the same register are desired, it is not necessary to continually send the Pointer Register bytes, because the TMP400 retains the Pointer Register value until it is changed by the next write operation. Note that register bytes are sent MSB first, followed by the LSB.

**TIMING DIAGRAMS**

Figure 13 to Figure 16 describe various operations on the TMP400. Bus definitions are given below. Parameters for Figure 13 are defined in Table 10.

**Bus Idle:** Both SDA and SCL lines remain high.

**Start Data Transfer:** A change in the state of the SDA line, from high to low, while the SCL line is high, defines a START condition. Each data transfer initiates with a START condition.

**Stop Data Transfer:** A change in the state of the SDA line from low to high while the SCL line is high defines a STOP condition. Each data transfer terminates with a repeated START or STOP condition.

**Data Transfer:** The number of data bytes transferred between a START and a STOP condition is not limited and is determined by the master device. The receiver acknowledges the transfer of data.

**Acknowledge:** Each receiving device, when addressed, is obliged to generate an Acknowledge bit. A device that acknowledges must pull down the SDA line during the Acknowledge clock pulse in such a way that the SDA line is stable low during the high period of the Acknowledge clock pulse. Setup and hold times must be taken into account. On a master receive, data transfer termination can be signaled by the master generating a Not-Acknowledge on the last byte that has been transmitted by the slave.

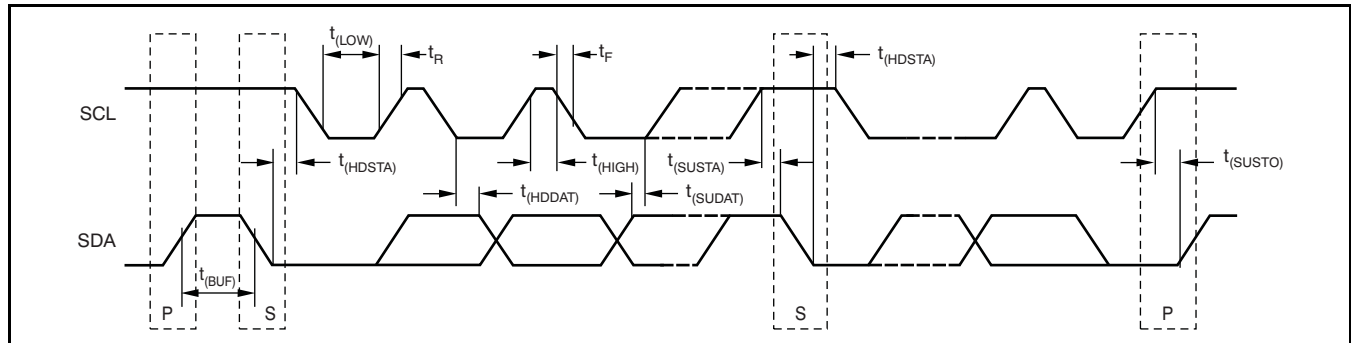
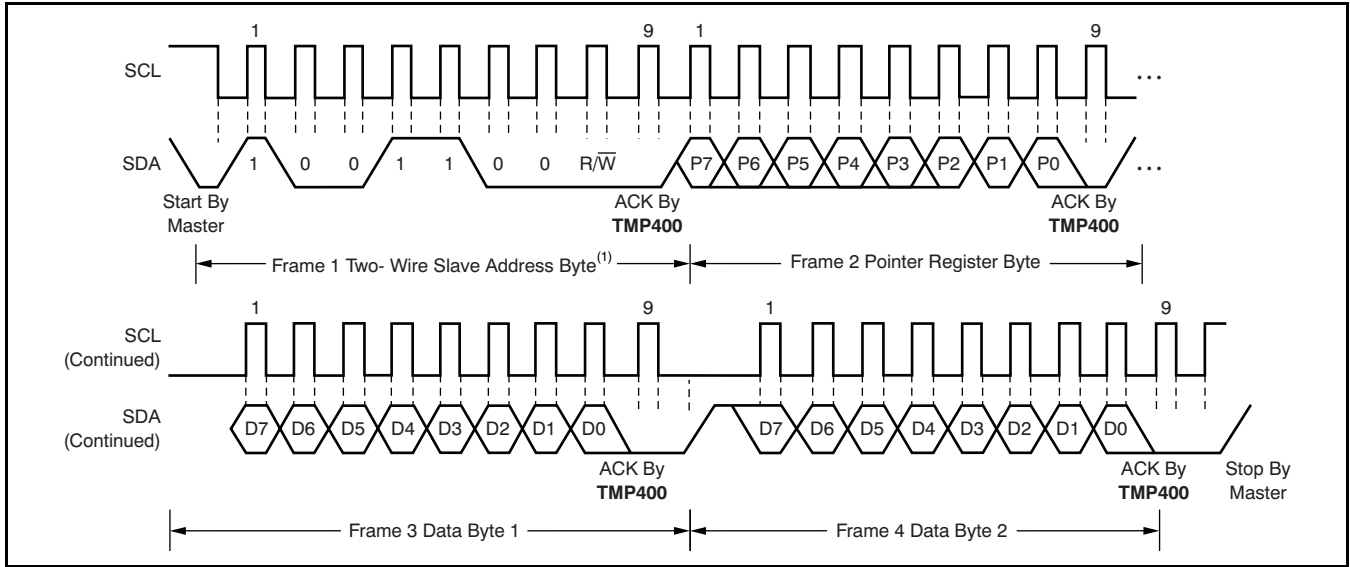

Figure 13. Two-Wire Timing Diagram

Table 10. Timing Diagram Definitions for Figure 13

PARAMETER		FAST MODE		HIGH-SPEED MODE		UNIT
		MIN	MAX	MIN	MAX	
SCL Operating Frequency	$f_{(SCL)}$	0.001	0.4	0.001	3.4	MHz
Bus Free Time Between STOP and START Condition	$t_{(BUF)}$	600		160		ns
Hold time after repeated START condition. After this period, the first clock is generated.	$t_{(HDSTA)}$	100		100		ns
Repeated START Condition Setup Time	$t_{(SUSTA)}$	100		100		ns
STOP Condition Setup Time	$t_{(SUSTO)}$	100		100		ns
Data Hold Time	$t_{(HDDAT)}$	0 <sup>(1)</sup>		0 <sup>(2)</sup>		ns
Data Setup Time	$t_{(SUDAT)}$	100		10		ns
SCL Clock LOW Period	$t_{(LOW)}$	1300		160		ns
SCL Clock HIGH Period	$t_{(HIGH)}$	600		60		ns
Clock/Data Fall Time	$t_F$		300			ns
Clock/Data Rise Time	$t_R$		300		160	ns
for SCL ≤ 100kHz	$t_R$		1000		160	ns

- (1) For cases with fall time of SCL less than 20ns and/or the rise time or fall time of SDA less than 20ns, the hold time should be greater than 20ns.
- (2) For cases with fall time of SCL less than 10ns and/or the rise or fall time of SDA less than 10ns, the hold time should be greater than 10ns.



(1) See Table 9 for all available addresses. A0 = 1 and A1 = 0 in this example.

Figure 14. Two-Wire Timing Diagram for Write Word Format

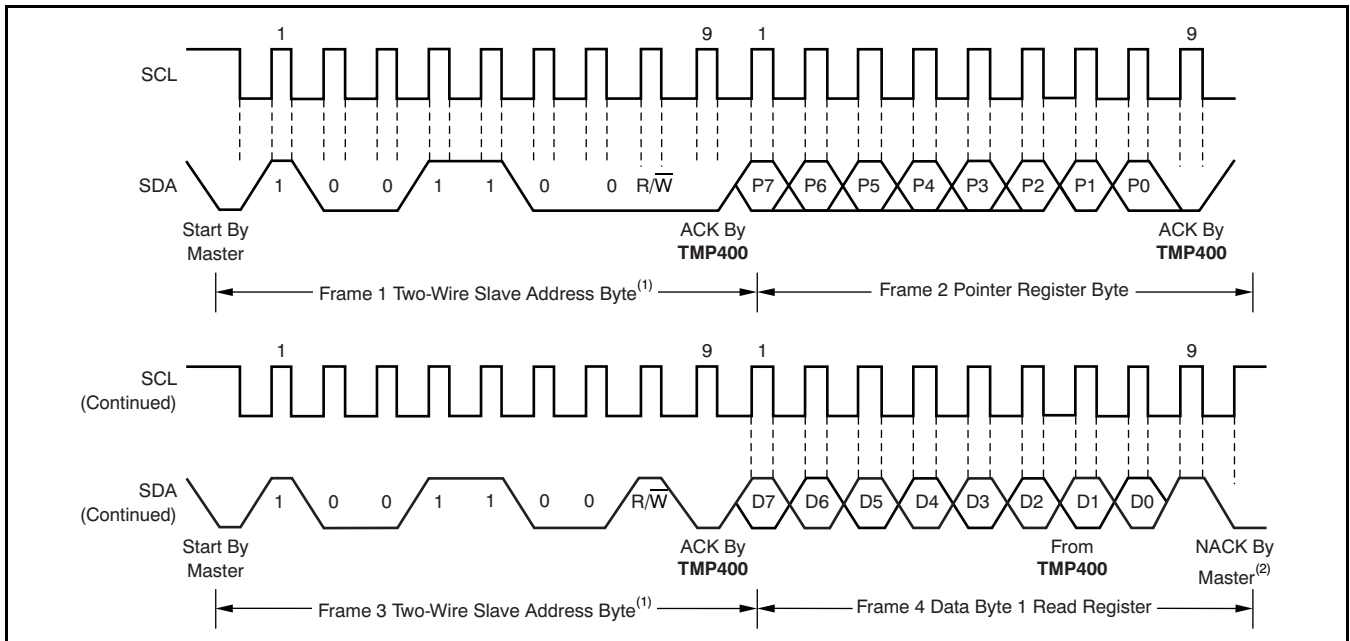

(1) See Table 9 for all available addresses. A0 = 1 and A1 = 0 in this example.

(2) Master should leave SDA high to terminate a single-byte read operation.

Figure 15. Two-Wire Timing Diagram for Single-Byte Read Format

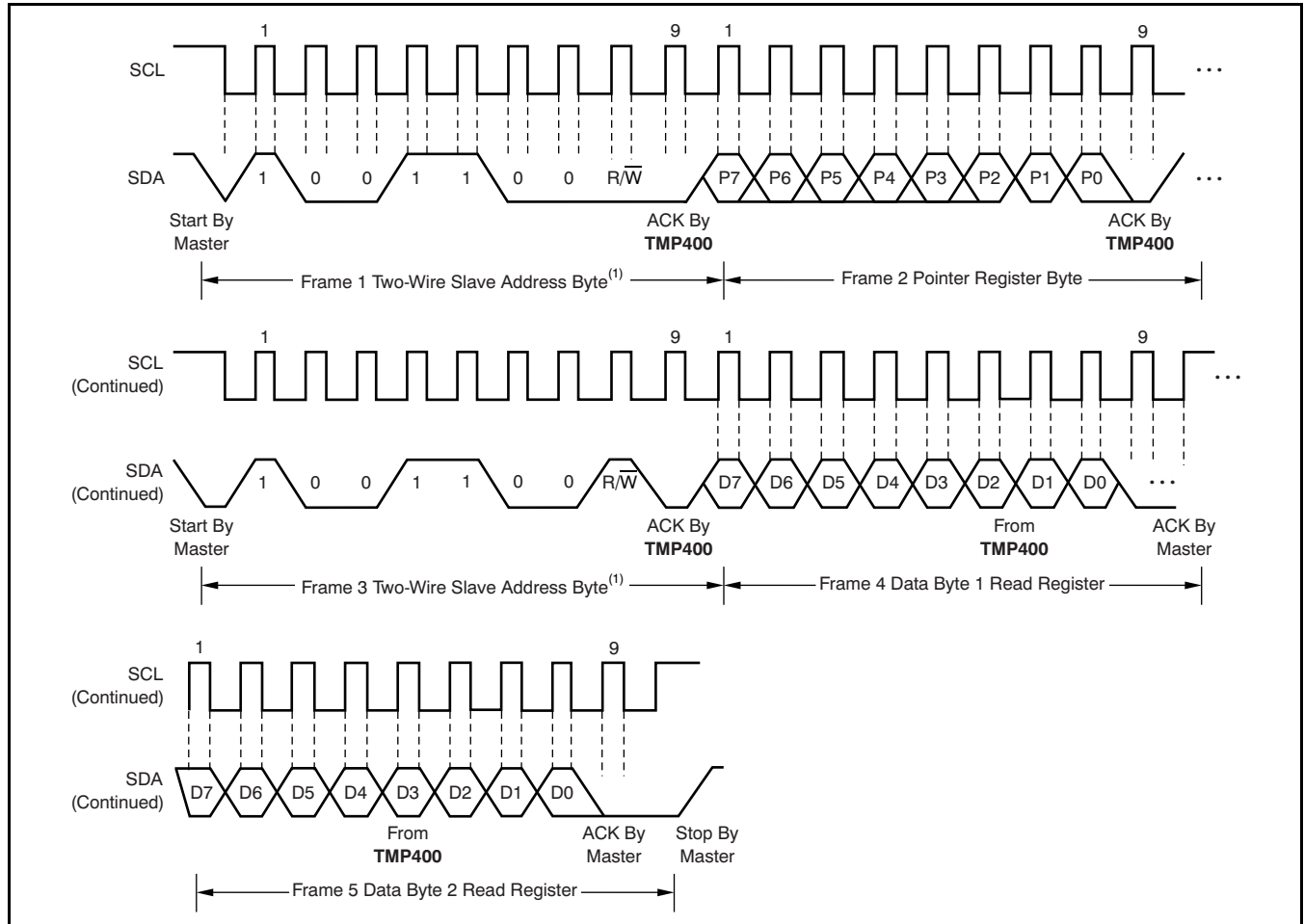

(1) See Table 9 for all available addresses. A0 = 1 and A1 = 0 in this example.

**Figure 16. Two-Wire Timing Diagram for Two-Byte Read Format**

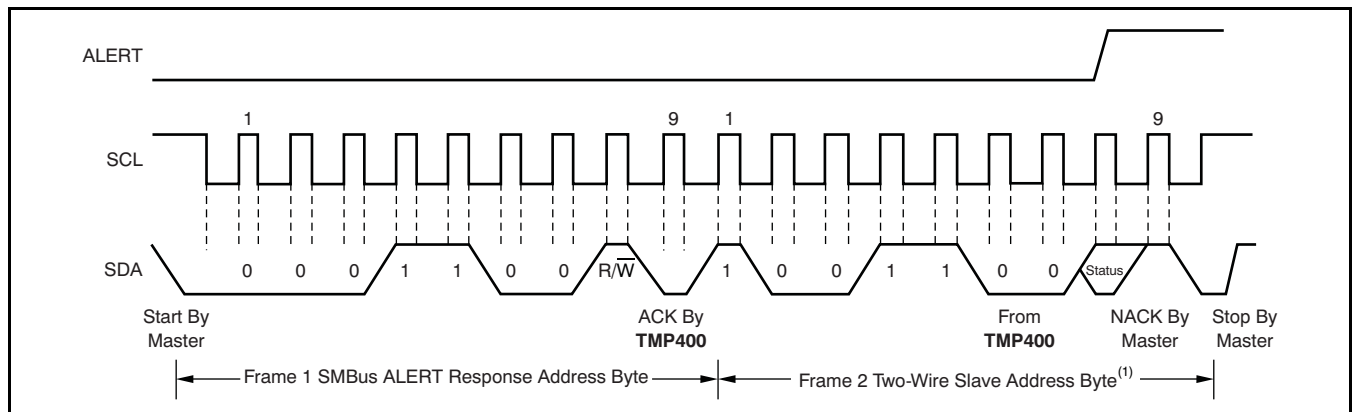

(1) See Table 9 for all available addresses. A0 = 1 and A1 = 0 in this example.

**Figure 17. Timing Diagram for SMBus ALERT**

## HIGH-SPEED MODE

In order for the Two-Wire bus to operate at frequencies above 400kHz, the master device must issue a High-speed mode (Hs-mode) master code (00001XXX) as the first byte after a START condition to switch the bus to high-speed operation. The TMP400 does not acknowledge this byte, but switches the input filters on SDA and SCL and the output filter on SDA to operate in Hs-mode, allowing transfers at up to 3.4MHz. After the Hs-mode master code has been issued, the master transmits a Two-Wire slave address to initiate a data transfer operation. The bus continues to operate in Hs-mode until a STOP condition occurs on the bus. Upon receiving the STOP condition, the TMP400 switches the input and output filter back to fast-mode operation.

## TIMEOUT FUNCTION

When bit 7 of the Consecutive Alert Register is set high, the TMP400 timeout function is enabled. The TMP400 resets the serial interface if either SCL or SDA are held low for 30ms (typical) between a START and STOP condition. If the TMP400 is holding the bus low, it releases the bus and waits for a START condition. To avoid activating the timeout function, it is necessary to maintain a communication speed of at least 1kHz for the SCL operating frequency. The default state of the timeout function is enabled (bit 7 = high).

## ALERT (PIN 11)

The  $\overline{\text{ALERT}}$  pin of the TMP400 is dedicated to alarm functions. This pin has an open-drain output that requires a pull-up resistor to V+. It can be wire-ORed together with other alarm pins for system monitoring of multiple sensors. The  $\overline{\text{ALERT}}$  pin is intended for use as an earlier warning interrupt, and can be software disabled, or masked.

The  $\overline{\text{ALERT}}$  pin (pin 11) asserts low when either the measured local or remote temperature violates the range limit set by the corresponding Local/Remote Temperature High/Low Limit Registers. This alert function can be configured to assert only if the range is violated a specified number of consecutive times (1, 2, 3, or 4). The consecutive violation limit is set in the Consecutive Alert Register. False alerts that occur as a result of environmental noise can be prevented by requiring consecutive faults.  $\overline{\text{ALERT}}$  also asserts low if the remote temperature sensor is open-circuit. When the MASK function is enabled (Configuration Register: bit 7 = 1),  $\overline{\text{ALERT}}$  is disabled (that is, masked).  $\overline{\text{ALERT}}$  resets when the master reads the device address, as long as the condition that caused the alert no longer persists, and the Status Register has been reset.

## STBY (PIN 15)

The TMP400 features a standby pin ( $\overline{\text{STBY}}$ ) that, when pulled low, disables the device. During normal operation  $\overline{\text{STBY}}$  should be tied high (V+). When  $\overline{\text{STBY}}$  is pulled low, the TMP400 is immediately disabled. If the TMP400 receives a One-Shot command when  $\overline{\text{STBY}}$  is pulled low, the command is ignored and the TMP400 continues to be disabled until  $\overline{\text{STBY}}$  is pulled high.

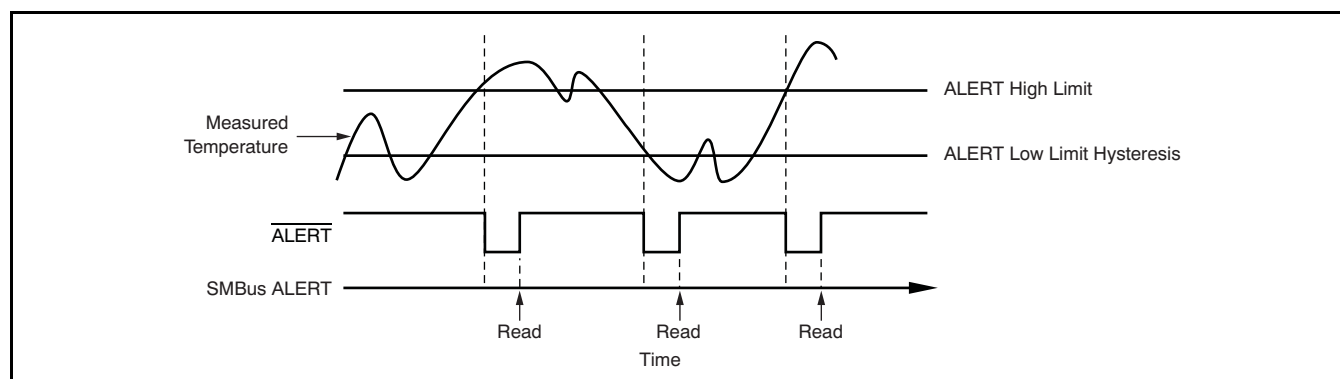

Figure 18. SMBus Alert Timing Diagram

## SMBUS ALERT FUNCTION

The TMP400 supports the SMBus Alert function. The  $\overline{\text{ALERT}}$  pin of the TMP400 may be connected as an SMBus Alert signal. When a master detects an alert condition on the  $\overline{\text{ALERT}}$  line, the master sends an SMBus Alert command (00011001) on the bus. If the  $\overline{\text{ALERT}}$  pin of the TMP400 is active, the device acknowledges the SMBus Alert command and respond by returning its slave address on the SDA line. The eighth bit (LSB) of the slave address byte indicates whether the temperature exceeding one of the temperature high limit settings or falling below one of the temperature low limit settings caused the alert condition. This bit is high if the temperature is greater than or equal to one of the temperature high limit settings; this bit is low if the temperature is less than one of the temperature low limit settings. See [Figure 17](#) for details of this sequence.

If multiple devices on the bus respond to the SMBus Alert command, arbitration during the slave address portion of the SMBus Alert command determines which device will clear its alert status. If the TMP400 wins the arbitration, its  $\overline{\text{ALERT}}$  pin becomes inactive at the completion of the SMBus Alert command. If the TMP400 loses the arbitration, the  $\overline{\text{ALERT}}$  pin remains active.

## SHUTDOWN MODE (SD)

The TMP400 Shutdown Mode allows the user to save maximum power by shutting down all device circuitry other than the serial interface, reducing current consumption to typically less than 3 $\mu$ A; see typical characteristic curve *Shutdown Quiescent Current vs Supply Voltage* ([Figure 10](#)). Shutdown Mode is enabled when the SD bit of the Configuration Register is high; the device shuts down once the current conversion is completed. When SD is low, the device maintains a continuous conversion state.

## SENSOR FAULT

The TMP400 senses a fault at the D+ input resulting from incorrect diode connection or an open circuit. The detection circuitry consists of a voltage comparator that trips when the voltage at D+ exceeds (V+) – 0.6V (typical). The comparator output is continuously checked during a conversion. If a fault is detected, the result reads 7FFh (0111 1111 1111b) and is used for the temperature measurement result; the OPEN bit (Status Register, [bit 2](#)) is set high, and, if the alert function is enabled,  $\overline{\text{ALERT}}$  asserts low.

When not using the remote sensor with the TMP400, the D+ and D– inputs must be connected together to prevent meaningless fault warnings.

## UNDERVOLTAGE LOCKOUT

The TMP400 senses when the power-supply voltage has reached a minimum voltage level for the ADC converter to function. The detection circuitry consists of a voltage comparator that enables the ADC converter after the power supply (V+) exceeds 2.45V (typical). The comparator output is continuously checked during a conversion. The TMP400 does not perform a temperature conversion if the power supply is not valid. The last valid measured temperature is used for the temperature measurement result.

## GENERAL CALL RESET

The TMP400 supports reset via the Two-Wire General Call address 00h (0000 0000b). The TMP400 acknowledges the General Call address and responds to the second byte. If the second byte is 06h (0000 0110b), the TMP400 executes a software reset, while latching the status of the address pins. This software reset restores the power-on reset state to all TMP400 registers, aborts any conversion in progress, and clears the  $\overline{\text{ALERT}}$  pin. If the second byte is 04h (0000 0100b), the TMP400 latches the status of the address pins, but does not reset. The TMP400 takes no action in response to other values in the second byte. A 500 $\mu$ s time delay must be taken after a general call command.

## IDENTIFICATION REGISTERS

The TMP400 allows for the Two-Wire bus controller to query the device for manufacturer and device IDs to allow for software identification of the device at the particular Two-Wire bus address. The manufacturer ID is obtained by reading from pointer address FEh. The device ID is obtained by reading from pointer address FFh. The TMP400 returns 55h for the manufacturer code and 01h for the device ID. These registers are read-only.

## FILTERING

Remote junction temperature sensors are usually implemented in a noisy environment. Noise is most often created by fast digital signals, and it can corrupt measurements. The TMP400 has a built-in 65kHz filter on the inputs of D+ and D– to minimize the effects of noise. However, a bypass capacitor placed differentially across the inputs of the remote temperature sensor is recommended to make the application more robust against unwanted coupled signals. The value of the capacitor should be between 100pF and 1nF. Some applications attain better overall accuracy with additional series resistance; however, this increased accuracy is setup-specific. When series resistance is added, the value should not be greater than 3k $\Omega$  and resistance correction must be enabled (RC = 1).

If filtering is needed, the suggested component values are 100pF and 50Ω on each input. Exact values are application specific. Resistance correction must be enabled to avoid offset correction.

## REMOTE SENSING

The TMP400 is designed to be used with either discrete transistors or substrate transistors built into processor chips and ASICs. Either NPN or PNP transistors can be used, as long as the base-emitter junction is used as the remote temperature sense. Either a transistor or diode connection can also be used; see [Figure 11](#).

Errors in remote temperature sensor readings are generally the consequence of the ideality factor and current excitation used by the TMP400 versus the manufacturer-specified operating current for a given transistor. Some manufacturers specify a high-level and low-level current for the temperature-sensing substrate transistors. The TMP400 uses 6μA for  $I_{LOW}$  and 120μA for  $I_{HIGH}$ . The TMP400 allows for different  $n$ -factor values; see the [N-Factor Correction Register](#) section.

The ideality factor ( $n$ ) is a measured characteristic of a remote temperature sensor diode as compared to an ideal diode. The ideality factor for the TMP400 is trimmed to be 1.008. For transistors whose ideality factor does not match the TMP400, [Equation 4](#) can be used to calculate the temperature error. Note that for the equation to be used correctly, actual temperature (°C) must be converted to Kelvin (°K).

$$T_{ERR} = \left[ \frac{n - 1.008}{1.008} \right] \times [273.15 + T(^{\circ}C)] \quad (4)$$

Where:

$n$  = Ideality factor of remote temperature sensor

$T(^{\circ}C)$  = actual temperature

$T_{ERR}$  = Error in TMP400 reading due to  $n \neq 1.008$

Degree delta is the same for °C and °K

For  $n = 1.004$  and  $T(^{\circ}C) = 100^{\circ}C$ :

$$T_{ERR} = \left[ \frac{1.004 - 1.008}{1.008} \right] \times (273.15 + 100^{\circ}C)$$

$$T_{ERR} = -1.48^{\circ}C \quad (5)$$

If a discrete transistor is used as the remote temperature sensor with the TMP400, the best accuracy can be achieved by selecting the transistor according to the following criteria:

1. Base-emitter voltage > 0.25V at 6μA, at the highest sensed temperature.

2. Base-emitter voltage < 0.95V at 120μA, at the lowest sensed temperature.
3. Base resistance < 100Ω.
4. Tight control of  $V_{BE}$  characteristics indicated by small variations in  $h_{FE}$  (that is, 50 to 150).

Based on these criteria, two recommended small-signal transistors are the 2N3904 (NPN) or 2N3906 (PNP).

## MEASUREMENT ACCURACY AND THERMAL CONSIDERATIONS

The temperature measurement accuracy of the TMP400 depends on the remote and/or local temperature sensor being at the same temperature as the system point being monitored. Clearly, if the temperature sensor is not in good thermal contact with the part of the system being monitored, then there will be a delay in the response of the sensor to a temperature change in the system. For remote temperature sensing applications using a substrate transistor (or a small, SOT23 transistor) placed close to the device being monitored, this delay is usually not a concern.

The local temperature sensor inside the TMP400 monitors the ambient air around the device. The thermal time constant for the TMP400 is approximately two seconds. This constant implies that if the ambient air changes quickly by 100°C, it would take the TMP400 about 10 seconds (that is, five thermal time constants) to settle to within 1°C of the final value. In most applications, the TMP400 package is in electrical (and therefore, thermal) contact with the printed circuit board (PCB), as well as subjected to forced airflow. The accuracy of the measured temperature directly depends on how accurately the PCB and forced airflow temperatures represent the temperature that the TMP400 is measuring. Additionally, the internal power dissipation of the TMP400 can cause the temperature to rise above the ambient or PCB temperature. The internal power dissipated as a result of exciting the remote temperature sensor is negligible because of the small currents used. For a 5.5V supply and maximum conversion rate of eight conversions per second, the TMP400 dissipates 1.82mW ( $PD_{IQ} = 5.5V \times 420\mu A$ ). If the  $\overline{ALERT}$  pin is sinking 1mA, an additional power of 0.4mW is dissipated ( $PD_{OUT} = 1mA \times 0.4V = 0.4mW$ ). Total power dissipation is then 2.22mW ( $PD_{IQ} + PD_{OUT}$ ) and, with an  $\theta_{JA}$  of 150°C/W, causes the junction temperature to rise approximately 0.333°C above the ambient.

**LAYOUT CONSIDERATIONS**

Remote temperature sensing on the TMP400 measures very small voltages using very low currents; therefore, noise at the IC inputs must be minimized. Most applications using the TMP400 will have high digital content, with several clocks and logic level transitions creating a noisy environment. Layout should adhere to the following guidelines:

1. Place the TMP400 as close to the remote junction sensor as possible.
2. Route the D+ and D– traces next to each other and shield them from adjacent signals through the use of ground guard traces, as shown in [Figure 19](#). If a multilayer PCB is used, bury these traces between ground or V<sub>DD</sub> planes to shield them from extrinsic noise sources. 5 mil (0.127mm) PCB traces are recommended.
3. Minimize additional thermocouple junctions caused by copper-to-solder connections. If these junctions are used, make the same number and approximate locations of copper-to-solder connections in both the D+ and D– connections to cancel any thermocouple effects.
4. Use a 0.1µF local bypass capacitor directly between the V+ and GND of the TMP400, as shown in [Figure 20](#). Minimize filter capacitance between D+ and D– to 1000pF or less for optimum measurement performance. This capacitance includes any cable capacitance between the remote temperature sensor and TMP400.
5. If the connection between the remote temperature sensor and the TMP400 is less than 8 inches (203.2mm), use a twisted-wire pair connection. Beyond 8 inches, use a twisted, shielded pair with the shield grounded as close to the TMP400 as possible. Leave the remote sensor connection end of the shield wire open to avoid ground loops and 60Hz pickup.

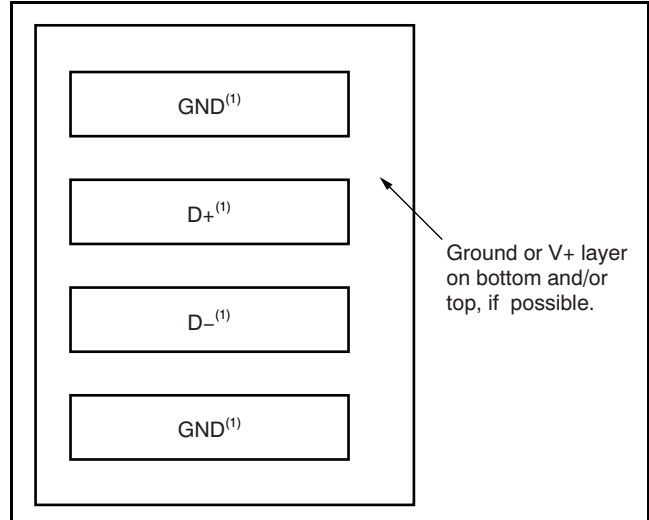

(1) 5mil traces with 5mil spacing.

**Figure 19. Example Signal Traces**

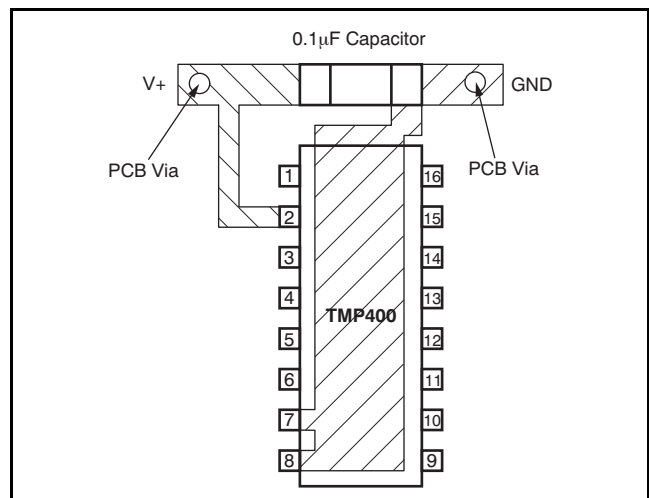

**Figure 20. Suggested Bypass Capacitor Placement**

**PACKAGING INFORMATION**

Orderable Device	Status <sup>(1)</sup>	Package Type	Package Drawing	Pins	Package Qty	Eco Plan <sup>(2)</sup>	Lead/Ball Finish	MSL Peak Temp <sup>(3)</sup>
TMP400AIDBQR	ACTIVE	SSOP/ QSOP	DBQ	16	2500	Green (RoHS & no Sb/Br)	CU NIPDAU	Level-2-260C-1 YEAR
TMP400AIDBQRG4	ACTIVE	SSOP/ QSOP	DBQ	16	2500	Green (RoHS & no Sb/Br)	CU NIPDAU	Level-2-260C-1 YEAR
TMP400AIDBQT	ACTIVE	SSOP/ QSOP	DBQ	16	250	Green (RoHS & no Sb/Br)	CU NIPDAU	Level-2-260C-1 YEAR
TMP400AIDBQTG4	ACTIVE	SSOP/ QSOP	DBQ	16	250	Green (RoHS & no Sb/Br)	CU NIPDAU	Level-2-260C-1 YEAR

<sup>(1)</sup> The marketing status values are defined as follows:

**ACTIVE:** Product device recommended for new designs.

**LIFEBUY:** TI has announced that the device will be discontinued, and a lifetime-buy period is in effect.

**NRND:** Not recommended for new designs. Device is in production to support existing customers, but TI does not recommend using this part in a new design.

**PREVIEW:** Device has been announced but is not in production. Samples may or may not be available.

**OBSOLETE:** TI has discontinued the production of the device.

<sup>(2)</sup> Eco Plan - The planned eco-friendly classification: Pb-Free (RoHS), Pb-Free (RoHS Exempt), or Green (RoHS & no Sb/Br) - please check <http://www.ti.com/productcontent> for the latest availability information and additional product content details.

**TBD:** The Pb-Free/Green conversion plan has not been defined.

**Pb-Free (RoHS):** TI's terms "Lead-Free" or "Pb-Free" mean semiconductor products that are compatible with the current RoHS requirements for all 6 substances, including the requirement that lead not exceed 0.1% by weight in homogeneous materials. Where designed to be soldered at high temperatures, TI Pb-Free products are suitable for use in specified lead-free processes.

**Pb-Free (RoHS Exempt):** This component has a RoHS exemption for either 1) lead-based flip-chip solder bumps used between the die and package, or 2) lead-based die adhesive used between the die and leadframe. The component is otherwise considered Pb-Free (RoHS compatible) as defined above.

**Green (RoHS & no Sb/Br):** TI defines "Green" to mean Pb-Free (RoHS compatible), and free of Bromine (Br) and Antimony (Sb) based flame retardants (Br or Sb do not exceed 0.1% by weight in homogeneous material)

<sup>(3)</sup> MSL, Peak Temp. -- The Moisture Sensitivity Level rating according to the JEDEC industry standard classifications, and peak solder temperature.

**Important Information and Disclaimer:**The information provided on this page represents TI's knowledge and belief as of the date that it is provided. TI bases its knowledge and belief on information provided by third parties, and makes no representation or warranty as to the accuracy of such information. Efforts are underway to better integrate information from third parties. TI has taken and continues to take reasonable steps to provide representative and accurate information but may not have conducted destructive testing or chemical analysis on incoming materials and chemicals. TI and TI suppliers consider certain information to be proprietary, and thus CAS numbers and other limited information may not be available for release.

In no event shall TI's liability arising out of such information exceed the total purchase price of the TI part(s) at issue in this document sold by TI to Customer on an annual basis.

**TAPE AND REEL INFORMATION**

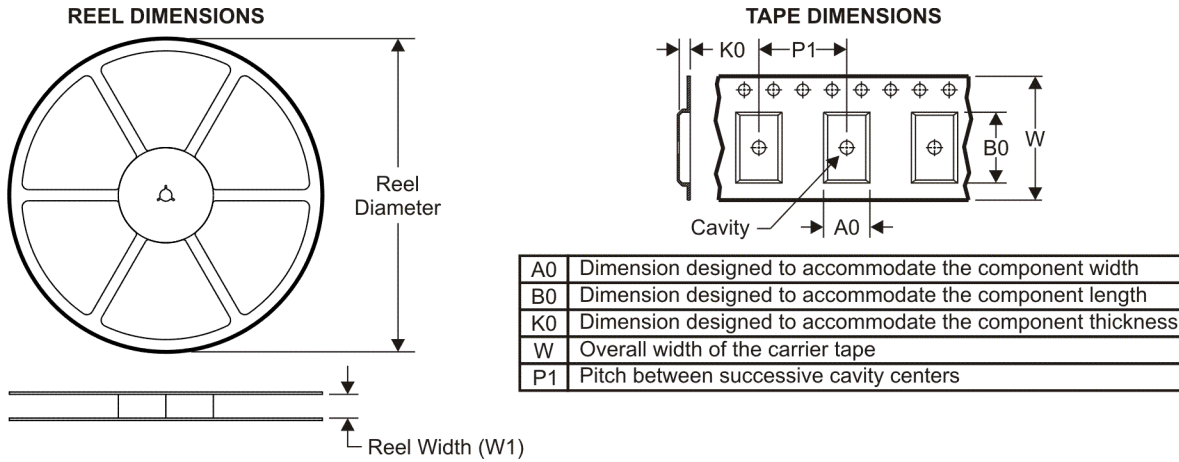

**QUADRANT ASSIGNMENTS FOR PIN 1 ORIENTATION IN TAPE**

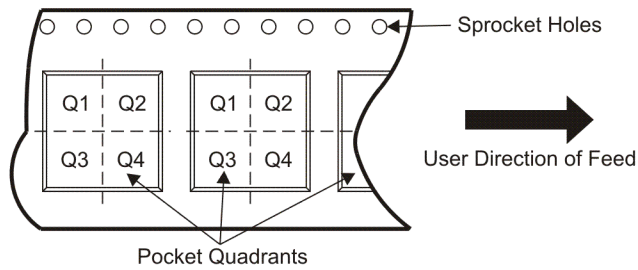

\*All dimensions are nominal

Device	Package Type	Package Drawing	Pins	SPQ	Reel Diameter (mm)	Reel Width W1 (mm)	A0 (mm)	B0 (mm)	K0 (mm)	P1 (mm)	W (mm)	Pin1 Quadrant
TMP400AIDBQR	SSOP/QSOP	DBQ	16	2500	330.0	12.4	6.4	5.2	2.1	8.0	12.0	Q1
TMP400AIDBQT	SSOP/QSOP	DBQ	16	250	180.0	12.4	6.4	5.2	2.1	8.0	12.0	Q1

**TAPE AND REEL BOX DIMENSIONS**

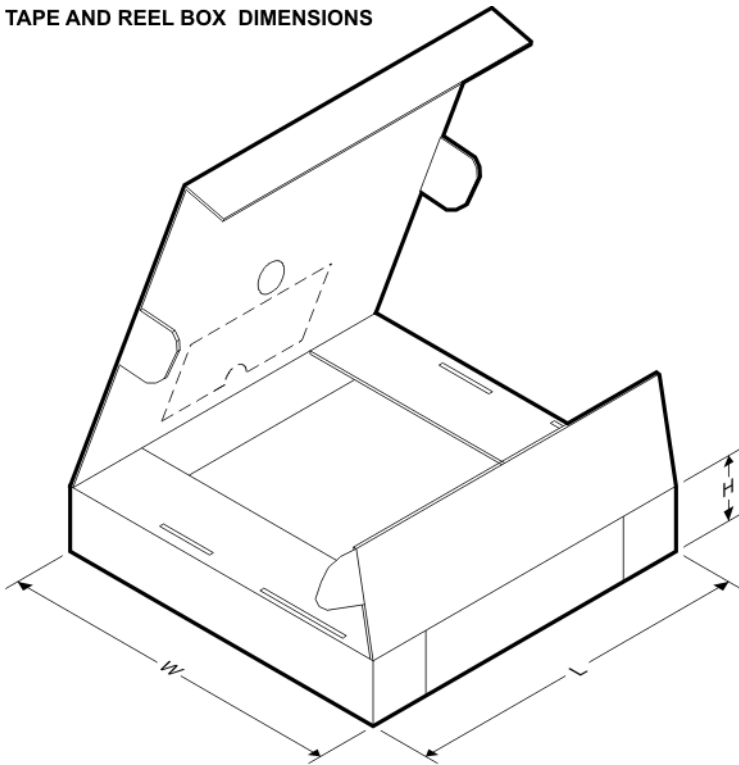

\*All dimensions are nominal

Device	Package Type	Package Drawing	Pins	SPQ	Length (mm)	Width (mm)	Height (mm)
TMP400AIDBQR	SSOP/QSOP	DBQ	16	2500	346.0	346.0	29.0
TMP400AIDBQT	SSOP/QSOP	DBQ	16	250	190.5	212.7	31.8





## IMPORTANT NOTICE

Texas Instruments Incorporated and its subsidiaries (TI) reserve the right to make corrections, modifications, enhancements, improvements, and other changes to its products and services at any time and to discontinue any product or service without notice. Customers should obtain the latest relevant information before placing orders and should verify that such information is current and complete. All products are sold subject to TI's terms and conditions of sale supplied at the time of order acknowledgment.

TI warrants performance of its hardware products to the specifications applicable at the time of sale in accordance with TI's standard warranty. Testing and other quality control techniques are used to the extent TI deems necessary to support this warranty. Except where mandated by government requirements, testing of all parameters of each product is not necessarily performed.

TI assumes no liability for applications assistance or customer product design. Customers are responsible for their products and applications using TI components. To minimize the risks associated with customer products and applications, customers should provide adequate design and operating safeguards.

TI does not warrant or represent that any license, either express or implied, is granted under any TI patent right, copyright, mask work right, or other TI intellectual property right relating to any combination, machine, or process in which TI products or services are used. Information published by TI regarding third-party products or services does not constitute a license from TI to use such products or services or a warranty or endorsement thereof. Use of such information may require a license from a third party under the patents or other intellectual property of the third party, or a license from TI under the patents or other intellectual property of TI.

Reproduction of TI information in TI data books or data sheets is permissible only if reproduction is without alteration and is accompanied by all associated warranties, conditions, limitations, and notices. Reproduction of this information with alteration is an unfair and deceptive business practice. TI is not responsible or liable for such altered documentation. Information of third parties may be subject to additional restrictions.

Resale of TI products or services with statements different from or beyond the parameters stated by TI for that product or service voids all express and any implied warranties for the associated TI product or service and is an unfair and deceptive business practice. TI is not responsible or liable for any such statements.

TI products are not authorized for use in safety-critical applications (such as life support) where a failure of the TI product would reasonably be expected to cause severe personal injury or death, unless officers of the parties have executed an agreement specifically governing such use. Buyers represent that they have all necessary expertise in the safety and regulatory ramifications of their applications, and acknowledge and agree that they are solely responsible for all legal, regulatory and safety-related requirements concerning their products and any use of TI products in such safety-critical applications, notwithstanding any applications-related information or support that may be provided by TI. Further, Buyers must fully indemnify TI and its representatives against any damages arising out of the use of TI products in such safety-critical applications.

TI products are neither designed nor intended for use in military/aerospace applications or environments unless the TI products are specifically designated by TI as military-grade or "enhanced plastic." Only products designated by TI as military-grade meet military specifications. Buyers acknowledge and agree that any such use of TI products which TI has not designated as military-grade is solely at the Buyer's risk, and that they are solely responsible for compliance with all legal and regulatory requirements in connection with such use.

TI products are neither designed nor intended for use in automotive applications or environments unless the specific TI products are designated by TI as compliant with ISO/TS 16949 requirements. Buyers acknowledge and agree that, if they use any non-designated products in automotive applications, TI will not be responsible for any failure to meet such requirements.

Following are URLs where you can obtain information on other Texas Instruments products and application solutions:

### Products

Audio	<a href="http://www.ti.com/audio">www.ti.com/audio</a>
Amplifiers	<a href="http://amplifier.ti.com">amplifier.ti.com</a>
Data Converters	<a href="http://dataconverter.ti.com">dataconverter.ti.com</a>
DLP® Products	<a href="http://www.dlp.com">www.dlp.com</a>
DSP	<a href="http://dsp.ti.com">dsp.ti.com</a>
Clocks and Timers	<a href="http://www.ti.com/clocks">www.ti.com/clocks</a>
Interface	<a href="http://interface.ti.com">interface.ti.com</a>
Logic	<a href="http://logic.ti.com">logic.ti.com</a>
Power Mgmt	<a href="http://power.ti.com">power.ti.com</a>
Microcontrollers	<a href="http://microcontroller.ti.com">microcontroller.ti.com</a>
RFID	<a href="http://www.ti-rfid.com">www.ti-rfid.com</a>
RF/IF and ZigBee® Solutions	<a href="http://www.ti.com/lprf">www.ti.com/lprf</a>

### Applications

Communications and Telecom	<a href="http://www.ti.com/communications">www.ti.com/communications</a>
Computers and Peripherals	<a href="http://www.ti.com/computers">www.ti.com/computers</a>
Consumer Electronics	<a href="http://www.ti.com/consumer-apps">www.ti.com/consumer-apps</a>
Energy and Lighting	<a href="http://www.ti.com/energy">www.ti.com/energy</a>
Industrial	<a href="http://www.ti.com/industrial">www.ti.com/industrial</a>
Medical	<a href="http://www.ti.com/medical">www.ti.com/medical</a>
Security	<a href="http://www.ti.com/security">www.ti.com/security</a>
Space, Avionics and Defense	<a href="http://www.ti.com/space-avionics-defense">www.ti.com/space-avionics-defense</a>
Transportation and Automotive	<a href="http://www.ti.com/automotive">www.ti.com/automotive</a>
Video and Imaging	<a href="http://www.ti.com/video">www.ti.com/video</a>
Wireless	<a href="http://www.ti.com/wireless-apps">www.ti.com/wireless-apps</a>

TI E2E Community Home Page

[e2e.ti.com](http://e2e.ti.com)

Mailing Address: Texas Instruments, Post Office Box 655303, Dallas, Texas 75265  
Copyright © 2011, Texas Instruments Incorporated